

Apach
COOK *Line*

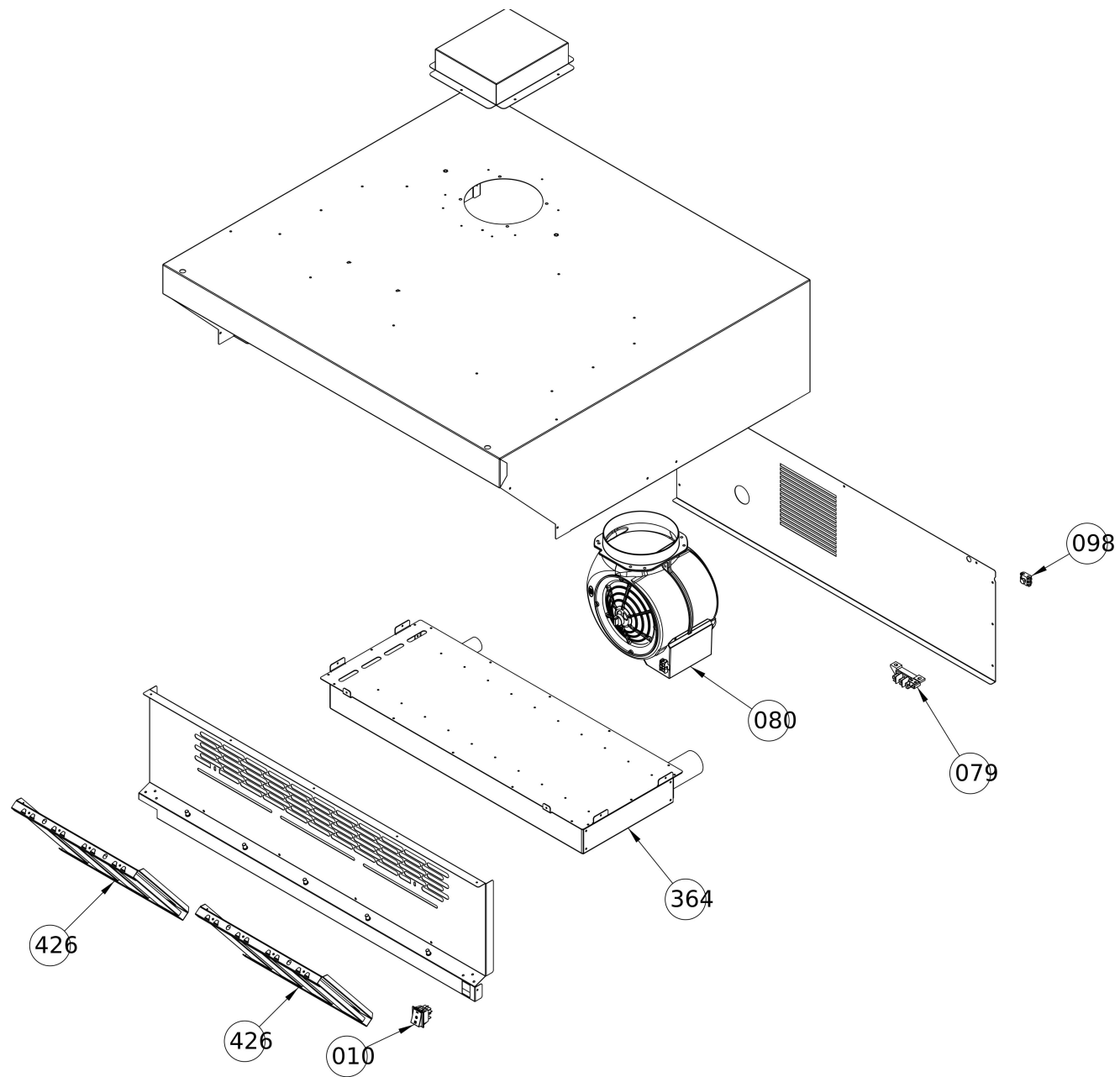

#	Code	Description	Specification	UM	Qty
010	20PUL00010	LIGHT SWITCH 3POS/6POLE 16A/250V		pz	1
079	020MOR0003	TERMINAL BLOCK		pz	1
080	20MOT00036	CENTRIFUGAL MOTOR 220 50/60HZ 1000M3/H		pz	1
098	020MOR0001	TERMINAL BLOCK BRIDGE		pz	1
364	85SCB00100	POVEGLIA CONDENSATION BOX		pz	1
426	85PSR00050	ASSY FRONT AIR VENT RH POSG		pz	2